

REBO[®] OUTDOOR Bamboo Products M/D series

**FUTURE
NEEDS BAMBOO**
MAKE IT HAPPEN





**800 MILLION
BAMBOO RESOURCE
AVAILABLE LOCALLY**

CONTENT

01 Company Profile



Technological
Characteristics 02



04 Facts About Products



Product Advantages 05



07 Product Data Sheet



Decking
Installation Manual 09



12 Decking
Maintenance Manual



Projects Reference 13



15 Wall Cladding
Installation Manual



Wall Cladding
Maintenance Manual 18



19 REBO® Warranty



COMPANY — PROFILE



- ISO9001, ISO14001
- 133,400 square meters
- 400,000 square meters annual
- 9 national invention patents and 77 utility model patents
- 20 years experience of hot-press technology

TECHNOLOGICAL CHARACTERISTICS



REBO® M-series:

REBO® with several unique techniques to remain the natural color, improve the M-SERIES products' durability and efficiently prevent the fungus growing from inside of bamboo stripes. With 160 ° C carbonization temperature, but higher heat pressure and heating time, to ensure the sugar, worm eggs and nutrient be removed efficiently. The finished products will apply the arising bamboo protective agent, in order to further inhibit the fungus' growth.

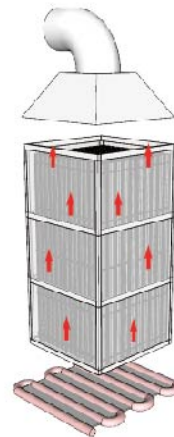

- **Self-developed drying technique**
To ensure the moisture content of bamboo stripes are equal from inside out, which the water does not accumulate inside the strips, and this environment will be hard for fungi to grow.

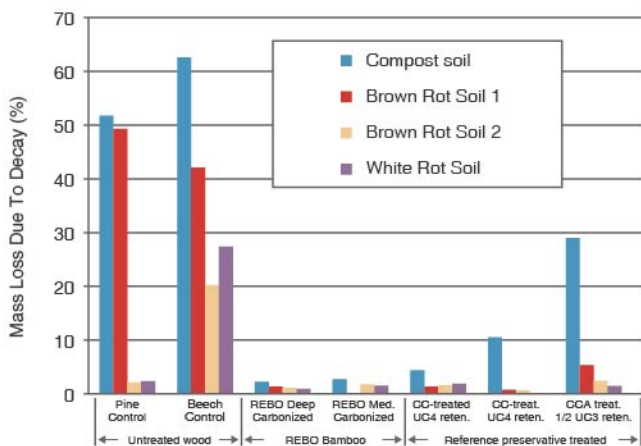

Durability of REBO Bamboo in comparison with untreated wood and preservative treated wood based on results from ENV 807

● Heat treatment

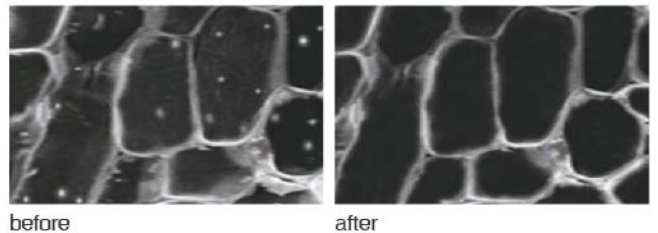

REBO® D-series:

Ultra-high temperature 220° C extreme heat treatment change the molecular order of bamboo fibers, to guarantee the fungus, worm eggs and all nutrients be removed and featured with super mothproof, anti-corrosion and anti-mildew effects.



FACTS ABOUT PRODUCTS



DURABILITY

- M&D series products with Class 1 durability (EN 350) tested following ENV 12038/ ENV 807 by RISE Bioeconomy.



USE CLASS

- M&D series products with Class 4 use (EN 335) tested following ENV 12038/ ENV 807 by RISE Bioeconomy.



ANTI-SLIP

- M&D series products with slip resistance R10 (oil-wet ramp test) in accordance with DIN51130:2014.
- dry 87/wet 53 (horizontal direction) , dry 83/wet 57 (longitudinal direction) in accordance with TS 16165:2012 Annex C by INTERTEK.



GREEN

- 5-year growing period
- endless resource
- eco-friendly



FORMALDEHYDE EMISSION

- In accordance with EN 13986:2004+ A1:2015 by SGS



TOUGHNESS

- Bending strength according to EN 408: 2012 (mean value) 87 N/mm² by EPH Laboratory
- Modulus of Elasticity in Bending according to EN 408:2012(mean value) 18700 N/mm² by EPH Laboratory



FIRE PROOF

- Reaction to fire according to EN 13501-1 by EPH Laboratory



HIGH HARDNESS

- Density 1.2g/cm³
- Brinell Hardness according to EN 1534:2011 107 N/mm²

PRODUCT

ADVANTAGES

Material	Eco-friendly	Impact toughness	Hydrolytic resistance	Rot rersistance
REBO® bamboo	It takes just 5 years to become useful material. This means a lot in globe resource sustainability. Utilization rate: over 90%!	Density: 1.2g/cm ³ Impact toughness more than 17320N High density/ hardness resistance+abraision-proof!	Thickness swelling rate of water absorption: 0.4% in 34 hours! (EU standard: <2%) strong anti-deformatin with high hydrosopicity.	Through our carboni-sation procedure and additionally our glue process: It is very hard to rot. Don' t need any preservations!
WPC/ engineered material	Made from raw plastic and sawdust. Plastic is made from petroleum, a limited resource. Recycle of wood-plastic is very hard.	Through the produc-tion method, wood-plastic is fragile, liable to fracture, low impact resistance and easily get scratch.	Waterproof and moistureproof	Wood-plastic is antiseptic, but with low weather durability.
Solid Wood Panel	Growth circle of high-class hardwood is 40-100 years, just the trunk is used. The Utilization rate is only 30%.	Only high-class hardwood, like rosewood has the high density and toughness for wearability and impact-resistance. But long growth time, excessive deforesta-tion, hardwood resource is getting rarer and rarer	Wood is strong in water absorption. Solid wood flooring waterproof depends on the coting. So it requires strong care in wetness protection. It easily gets bubble and transformation.	All antiseption techniques for wood are with method of strong chemical infiltration. In taking care of environmental protetion level, the antiseption is far not so high like our strand wooven bamboo.



Material	Formaldehyde Emission	Mothproofing	Fire resistance	Colour/ texture	Quality grade	Time
REBO® bamboo	Lower than 0.050mg/m ³ . It meets the standard of Europe and USA complete. Much lower as the national standard. Green & Environment-friendly!	Carbonization technology remove starch, sugar and protein, and kill insect eggs and fungi, That generate the extreme hardness and Strong moth-proov-ing.	Polymerization and curing of phenolic resin for food packaging with high fire resistance and high flame retardant coeffi-cient.	The grain of bamboo after processing is similar to high end rosewood.	Quality and Features are the same as tropical wood.	30 years
WPC/ engineered material	The range of the product quality is very wide and depend according to the production method.	Termite prevention is good and better than wood	Compare to normal wood it is relatively high in fireproof.	Artificial texture, low durability in impact, the looking is not appealing.	Low weather durability, low wear resistance.	3 - 6 years
Solid Wood Panel	Different brand and technique has its own formalde-hyde standard. Consoliated wooden floor is higher in formal-dehyde outgiving.	Termite prevention can only realized with preventive coating or applied surface	Easy to burn as the natural property of wood fiber	Rosewood with outstanding texture is very high in price.	Depends on the species, quality rangees a lot.	3 - 8 years

PRODUCT

DATA SHEET

Product Description

REBO® products choose the fast growing moso bamboo as raw material, are manufactured by Fujian Golden Bamboo Industry Co., Ltd. During years of researched and self-developed producing technique, all range of REBO® outdoor products have characteristic of high density(1200kg/m³), durability Class 1 (EN350), fire proof, water proof, anti-mildew, anti – corrosion, and slip-resistance(R10). REBO® bamboo products will be your ideal for outdoor decking, cladding, fencing and furniture etc.

Quality and Appearance

Appearance	Outdoor / T & G head / length sides grooved / oiled	
Dimension	1850 x 140 x 18 / 20 / 30 mm	
Moisture content	6-15%	
4h Circulating boiled thickness expansion rate	≤ 10% (M-Series)	≤ 5% (D-Series)
72h Thickness expansion ratio	≤ 18% (M-Series)	≤ 10% (D-Series)
Density	1.2g/cm ³	
Note:Please visit the website for more details.		



F021
flat surface

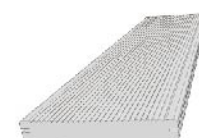

F121
small wave surface

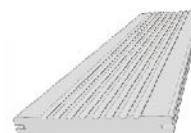

F321
big wave surface



T & G head

Technical Data

Test Items	Test Results	Testing Standard
Brinell hardness	107N / mm ²	EN 1534 : 2011
Bending strength	87N / mm ²	EN 408 : 2012
Modulus of elasticity in bending(mean value)	18700N / mm ²	EN 408 : 2012
Durability	Class 1 / ENV807 ENV12038	EN350
Use class	Class 4	EN335
Reaction to fire	Bfl-s1	EN13501-1
Slip resistance(Oil-wet ramp test)	R10	DIN 51130:2014
Slip resistance (PTV20)	86(Dry), 53(Wet)	CEN/TS 16165:2012 Annex C
Formaldehyde Emission	E1	EN 717-1:2004

Disclaimer

REBO® products will only apply to the normal environment and use conditions of buildings. It does not include the damage caused by misuse, accident, natural disaster and force majeure, damage caused by obvious surface nick or destroy or erection joint, chromatic aberration caused by illumination, natural oil loss of surface caused by seasonal climatic variation, or damage caused by improper installation, maintenance, cleaning, surface paint care, mechanical or chemical contamination.

The REBO® planks are natural forest products, with differences in color, texture, and surface. The color may change based on the maintenance period and service time. The surface and end face may produce small cracks due to their different air shrinkage bulking factors. The surface may become coarse after a certain period of time, due to the constant expansion and contraction caused by

different local temperatures and climate changes. The product may have slightly dimensional changes or produce a tile-shaped deformation after installation.

These products are not recommended to be used barefoot, there always a risk of formation of splinters, though its splinters are smaller than tropical hardwood. After the decking is installed, especially nearby swimming pool area, regular maintenance and apply water-based oil afterward is required to smoothen the surface and reduce such circumstances. If not do so, it's likely to cause the injury by walking as barefoot.

The manufacturer cannot be held liable for these phenomena.



Grange Hotel, Sri Lanka ▶



Alon Building, Tel-aviv, Israel ▲



Administration Center Square, Beijing ▲

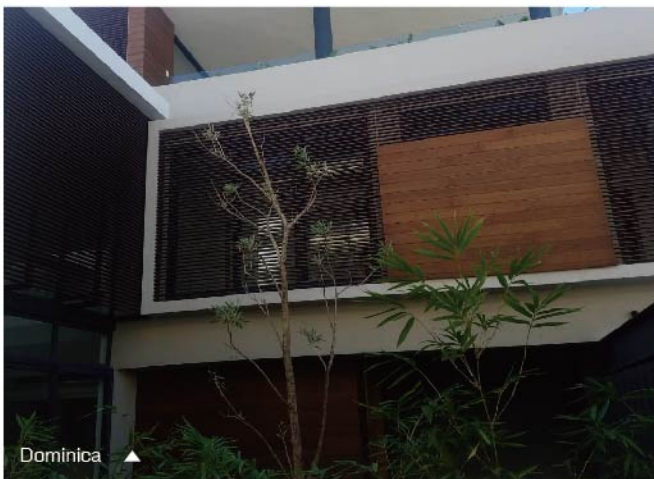

Dominica ▲



Tianlanhui Estate, Hainan ▲

DECKING

INSTALLATION MANUAL

Remark: the decks in the picture are only for reference, the exact color should be subject to the actual products.

Material & Tools



F311



F321



Joist

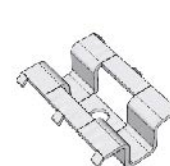

DC 05-1



DC 05-2

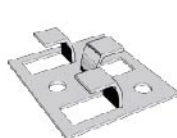

DC 07

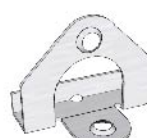

DC 06



Stainless Screws



Electric Saw



Steel Tape



Spirit Level



Rubber Hammer

Electric Screw
Driver

Consideration

- ❶ Before installing, please keep the products in dry and shade place, avoid the sunshine and the rain. Defects in surface caused by improper storage, is insufficient to cause customer complaint.
- ❷ Before installation, clean up the worksite, make sure the basic is flat and stable, the drainage is smooth and conforms with the requirement of the construction design.
- ❸ The joists should be fixed on stable cement-blocks or cement-tiles. Ensure decking slope 1-2 degrees from level in order to shed water.
- ❹ The distance between the joists must be between 450 to 500mm. By a deck of 1860mm length need min.5 joists.
- ❺ Distance from floor to the bottom of the decking should be 80-150mm.

■ Instructions

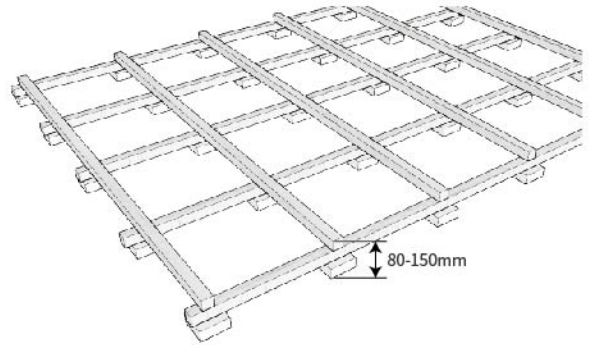
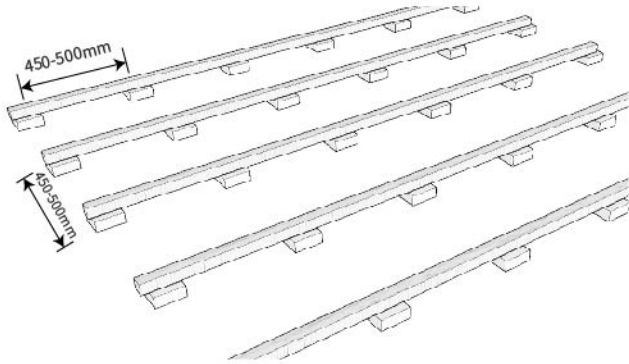

Minimum

Cement-tiles under the joists

Professional

Use double-layer joists on cement-tiles for long-term stability

There are different clips can be used for installation in order to do water draining and prevent dry shrinkage and wet swelling.

You can use clip DC 06 for beginning and ending decks.

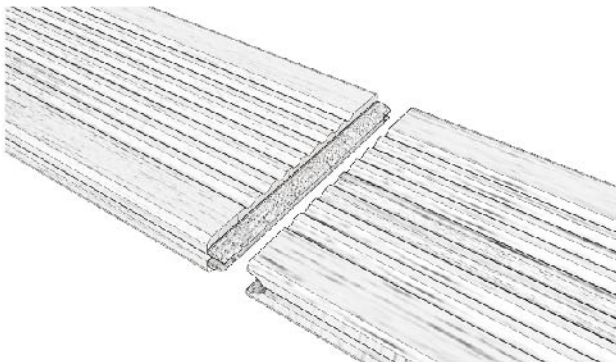
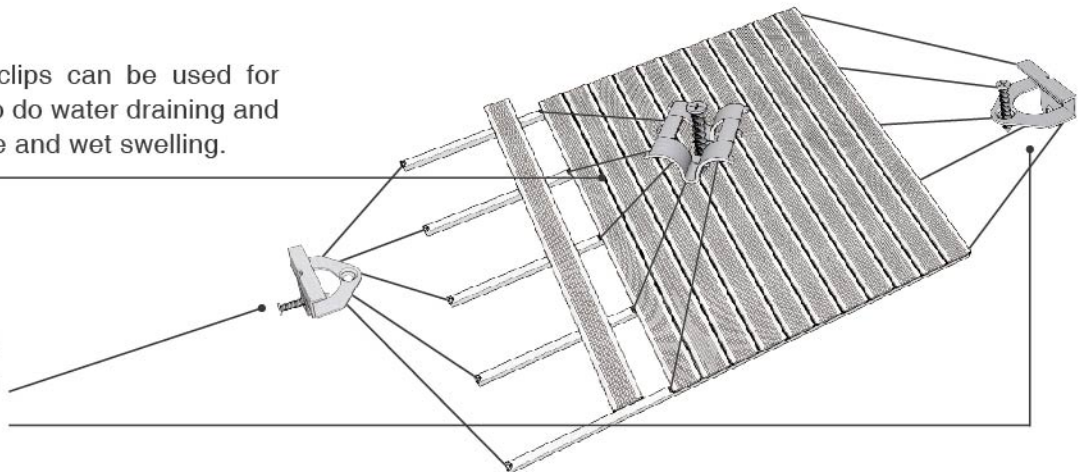

Deck with tongue & groove in head side is suggested.

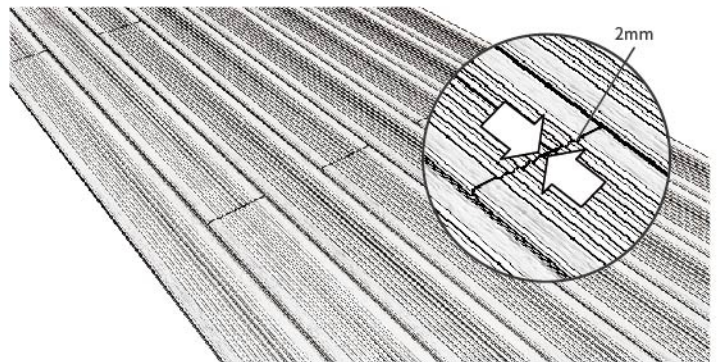

For deck without T&G, when head side connection is needed, please hold 2mm distance between.

■ Installation Methods

- ❶ Decking with symmetrical grooved in two length sides can be fixed with clip DC 05-1. Distance between the deck is about 6-7mm after installation.

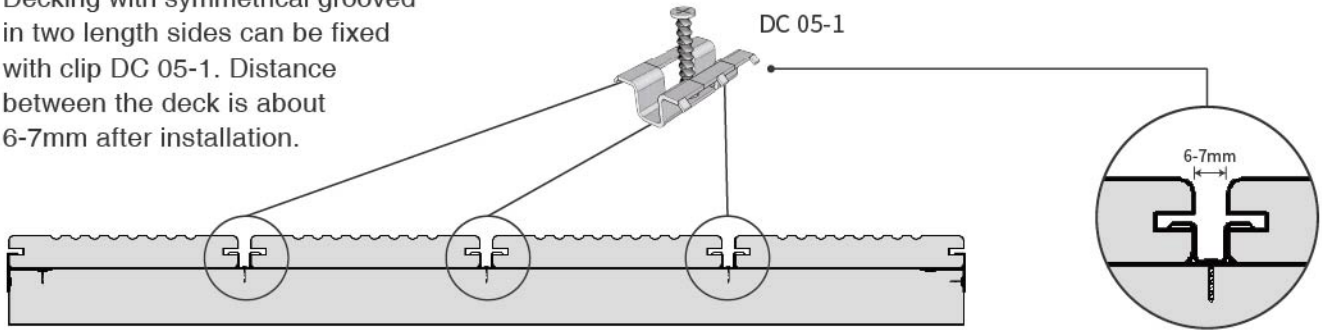

- ❷ Decking with H & L grooved in two length sides can be fixed with clip DC 05-2. Distance between the deck is about 5mm after installation.

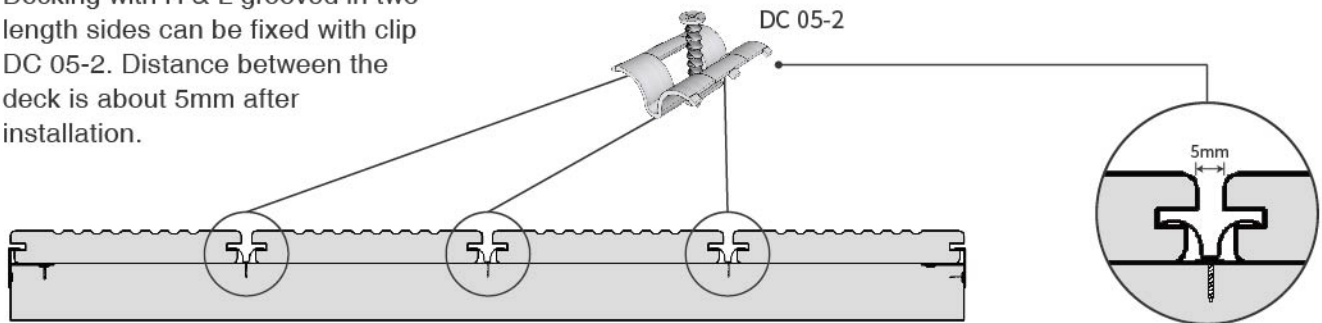

- ❸ Decking with symmetrical or H & L grooved in two length sides can be fixed with clip DC 07. Distance between the deck is about 4mm after installation.

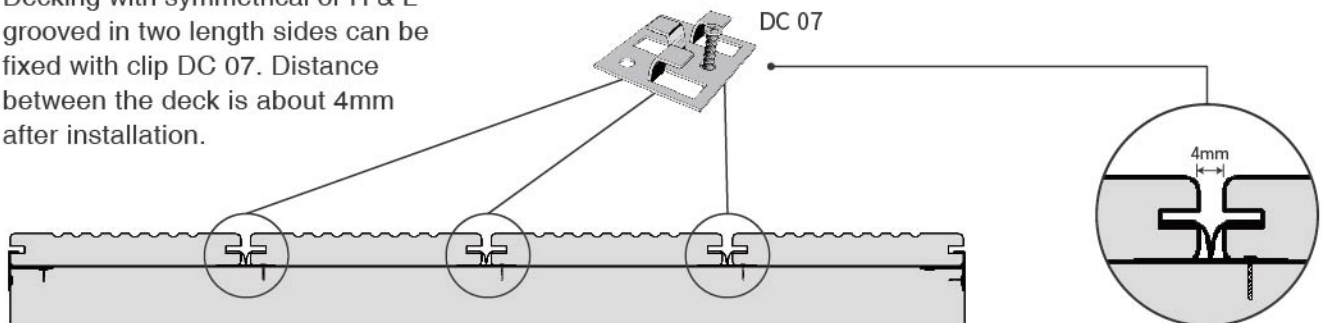

DECKING

MAINTENANCE MANUAL

First maintenance is required directly after installation, afterwards six months one time suggested. Apply outdoor water-based oil after cleaning up the surface.

Select suitable tool for cleaning according to your decking scale.



❶

Clean the decking: wash it with water or use special cleaner to get rid of mucedine and dirt then clean it with brush.

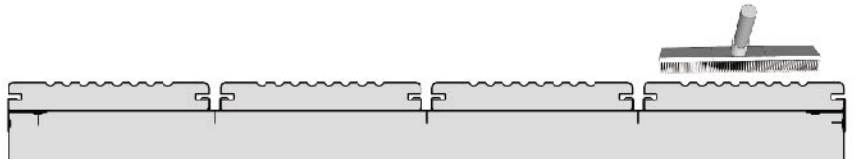

❷

Make sure the decking get dry naturally and apply outdoor water-based oil.

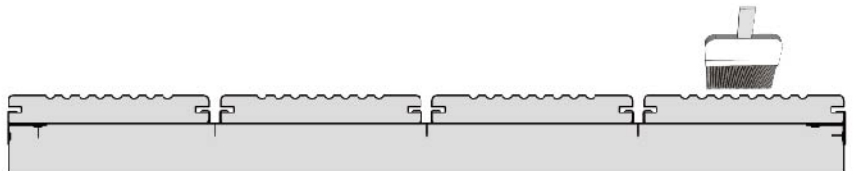

❸

Protect the maintained area until oil gets dry naturally.

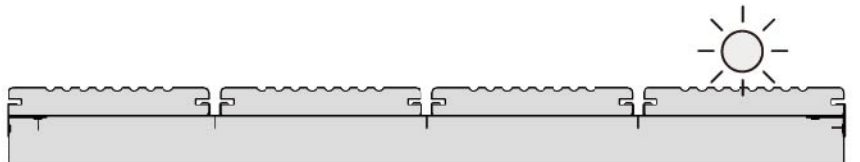

■ M-Series



After Installation 2 Years After Use After Cleaning After Maintenance

■ D-Series



After Installation 2 Years After Use After Cleaning After Maintenance

PROJECTS

REFERENCE



Smart China Expo, Chongqing ▲



Alma Resort, Vietnam ▲



Weinan People's Park, Shaanxi ▲



Coffee Street, Xiamen ▲

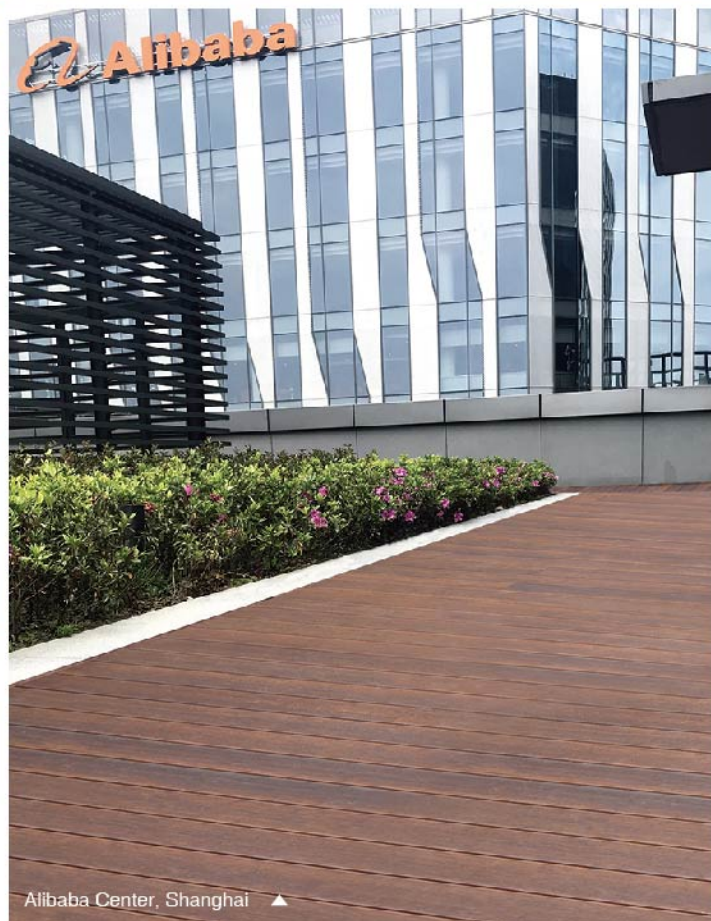

Alibaba Center, Shanghai ▲



East Lake VR Town, Fuzhou ▲



Tianbao Riverside Park, Zhangzhou ▲



Simpson's Forest Hotel, Sri Lanka ▲

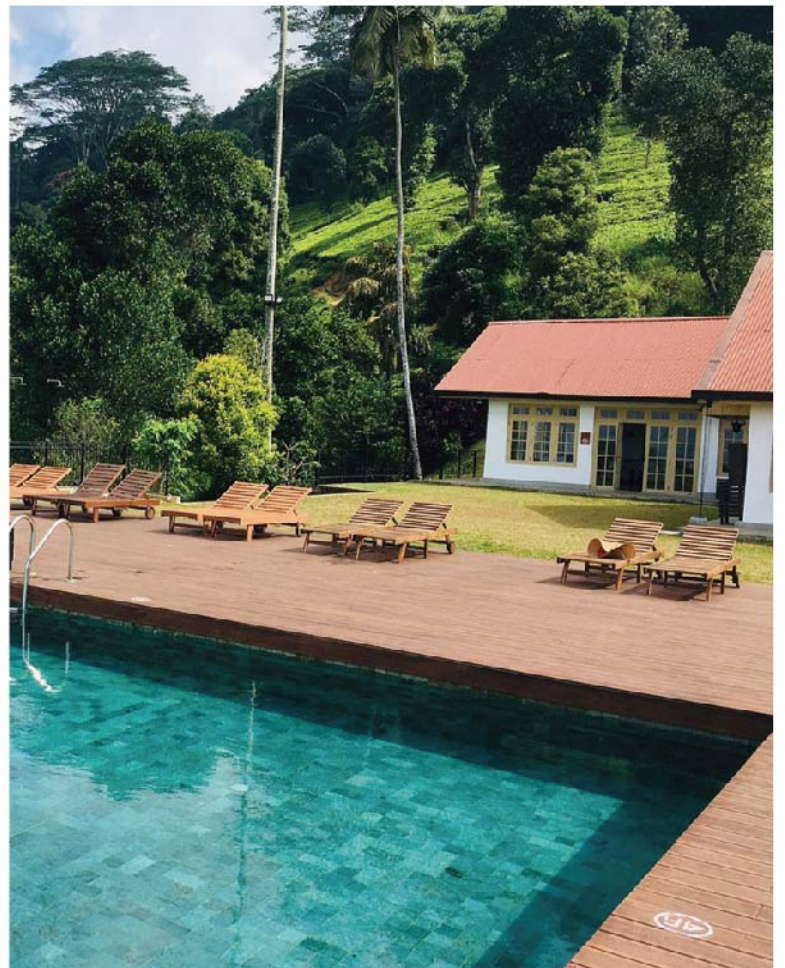

WALL CLADDING

INSTALLATION MANUAL

Remark: the wall panels in the picture are only for reference, the exact color should be subject to the actual products.

■ Material & Tools

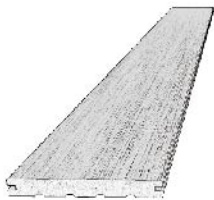

W021



W031

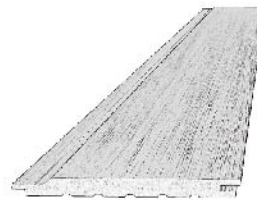

W041-1

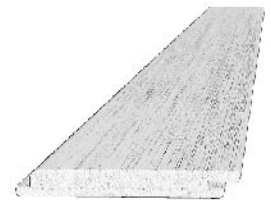

W091



Joist

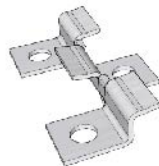

DC 01-1

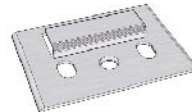

DC 04

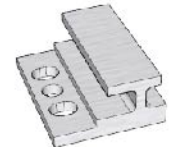

DC 07



Stainless Screws



Electric Saw



Nail Of Pneumatic



Steel Tape



Spirit Level



Rubber Hammer



Electric Screw Driver

■ Consideration

- ① Before installing, please keep the products in dry and shade place, avoid the sunshine and the rain. Defects in surface caused by improper storage, is insufficient to cause customer complaint.
- ② Before installation, clean up the wall, make sure it's flat and stable.If there is no solid masonry on the substrate, the joist must be fixed to the main body of the building in a solid frame and in accordance with the relevant building regulations and design requirements.
- ③ The distance between the joists must be between 400 to 500mm,by a wall cladding of 1860mm length need minimum 5 joists.
- ④ Make sure the wall and wall cladding keep dry before installation.

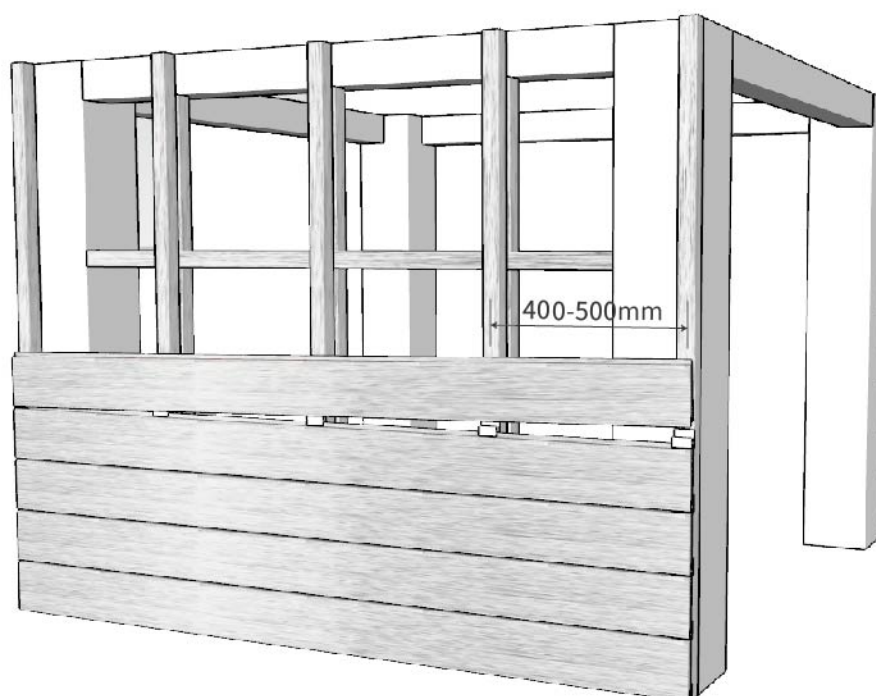
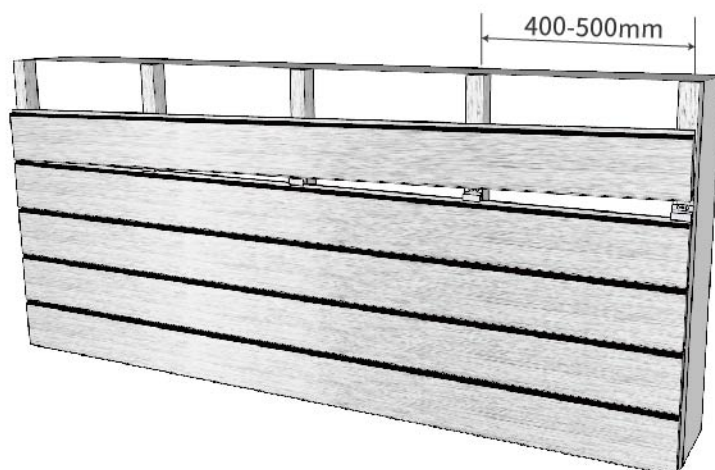

■ Installation

The correct order of wall installation should be bottom-up. First of all, the first wall panel should be fixed on the bottom joist of the wall which needs to be installed, at the same time, the raised part of the clips are embedded in the groove of the wall panel and locked with screws. (Notice: if REBO joist used, always pre-drill the holes to avoid cracking! Use the joists in direction from top.)

1 W021

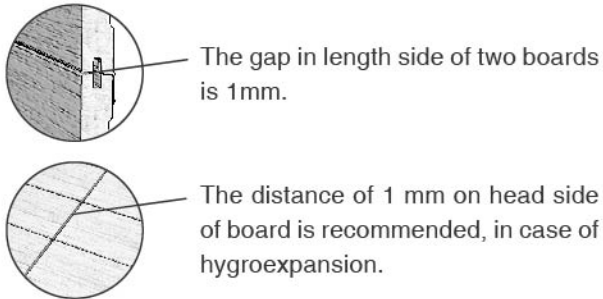
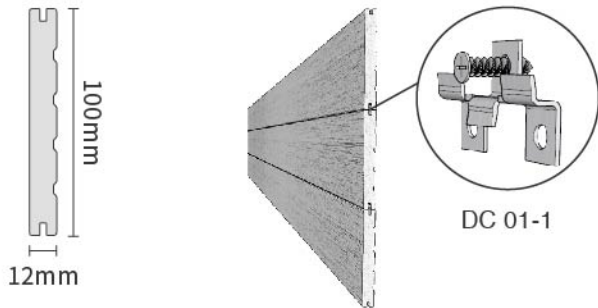

2 W041-1

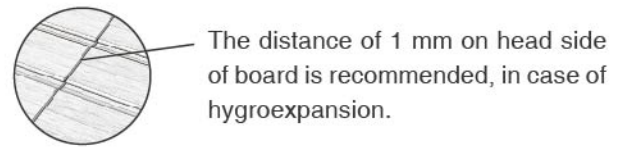
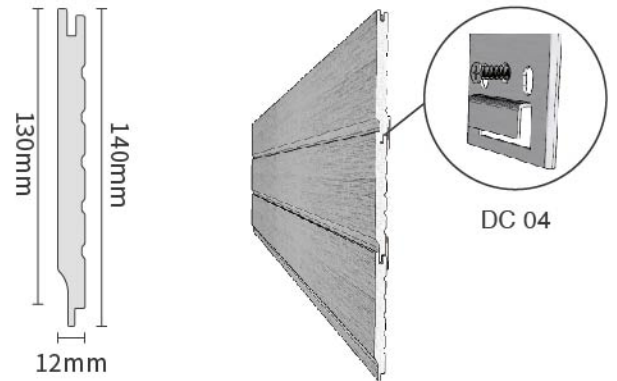

3 W091

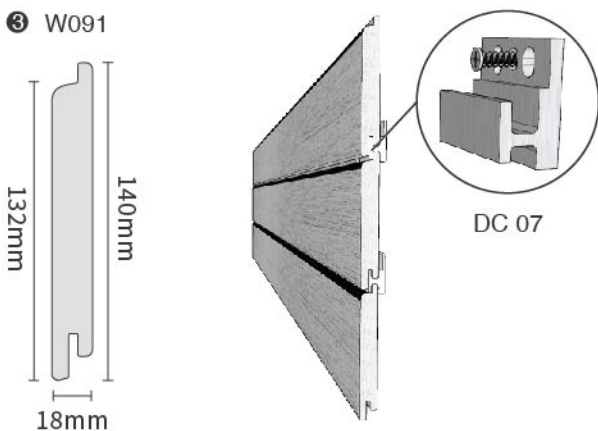

4 W031

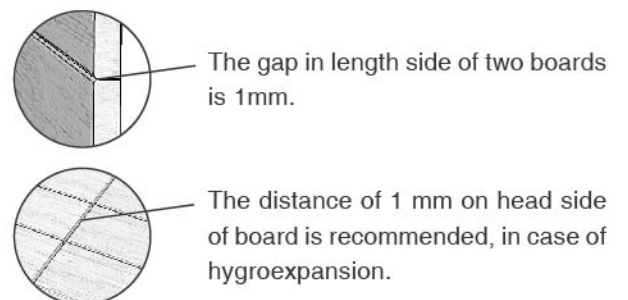
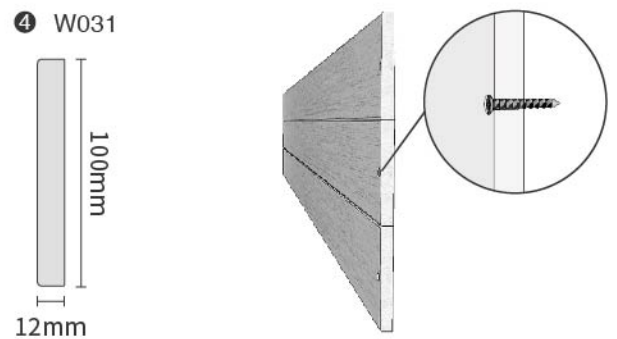

WALL CLADDING MAINTENANCE MANUAL

First maintenance is required directly after installation, afterwards six months one time suggested. Apply outdoor water-based oil after cleaning up the surface.

Select suitable tool for cleaning according to the fixing scale.



❶ Clean the wall panels: wash it with water or use special cleaner to get rid of mucedine and dirt then clean it with brush.



❷ Make sure the wall panels get dry naturally and apply outdoor water-based oil.



❸ Protect the maintained area until oil gets dry naturally.

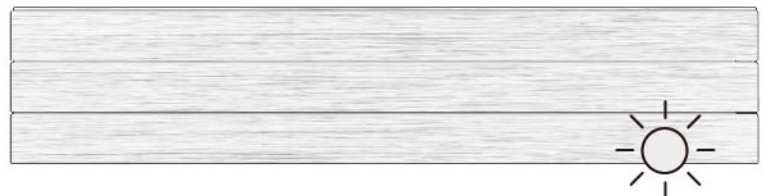

■ M-Series



After Installation 2 Years After Use After Cleaning After Maintenance

■ D-Series



After Installation 2 Years After Use After Cleaning After Maintenance

REBO®

WARRANTY

Dear customer: First of all, thank you for choosing our REBO® bamboo products!

Fujian Golden Bamboo Industry Co., Ltd. since its foundation, has always taken the product quality as its core to participate in market competition. It has established a strict quality inspection system and scientific quality inspection standards, which can be used for strict controlling and managing all links related to product quality. We hereby promise that the REBO® bamboo M/D SERIES products have a guarantee period of thirty years (Residential) and twenty years (Commercial) from the date of purchase by following provisions.

1.Scope of warranty

- This warranty only applies to the normal environment and use conditions of buildings. It does not include the damage caused by misuse, accident, natural disaster and force majeure, damage caused by obvious the surface nick or destroy or erection joint, chromatic aberration caused by illumination, natural oil loss of the surface caused by seasonal climatic variation, or damage caused by improper installation, maintenance, cleaning, the surface paint care, mechanical or chemical contamination.
- The REBO® planks are natural bamboo products, with differences in color, texture and the surface. The color may change based on the maintenance period and service time. The change in color and surface coating degradation are insufficient to cause customer complaints.
- The surface and end face may produce small cracks due to their different air shrinkage bulking factors. This phenomenon is common to most wood products, insufficient to cause customer complaints.
- The surface may become coarse after a certain period, due to the constant expansion and contraction caused by different local temperatures and climate changes. This phenomenon is common to most wood products, insufficient to cause customer complaints.
- The product may have slight dimensional changes or produce a tile-shaped deformation after installation. This phenomenon is common to most wood products, insufficient to cause customer complaints.
- Outdoor bamboo decking is a natural product, not recommended to be used by barefoot, there is always a risk of formation of splinters, though its splinters are smaller than tropical hardwood. After the decking is installed, especially nearby swimming pool area, regular maintenance and apply water-based oil afterward is required to smoothen the surface and reduce such circumstances. Furthermore,

please use carefully, particularly around the swimming pool and immediately maintaining decking once the splinters have found. The manufacturer is not responsible for any injury caused by the user's improper use of these bamboo products.

- Before installing, please keep the products in dry and shade places, avoid the sunshine and the rain. Defects on the surface caused by improper storage, insufficient to cause customer complaints.

2.Warranty conditions

- Products must be used in strict accordance with the installation and Maintenance Manual. Customized products are insufficient to cause customer complaints.
- The product should be maintained for the first time after installation, and maintained every six months after that, by cleaning the surface and applying the water-based oil. It's insufficient to cause customer complaints if the product is maintained not as required..

3.Warranty content

- This warranty applies to the buyer's lawful rights and interests and also includes the buyer's rights exercised to the seller. It is limited to the original purchaser, which is not transferable.
- If the customer complaints (Residential or Commercial) is generated within two years from the date of purchase from Fujian Golden Bamboo Industry Co., Ltd. we will reserve the right to either repair the defects or provide the products for free to the original purchaser, including the local replacement cost of labor and freight.
- If the original purchaser makes a valid warranty claim during years three to twenty (Commercial) / thirty (Residential) after the original purchase, then the recovery is indicated by the following chart.

Year of Claim	Recovery		REMARK
	Residential (30 Years)	Commercial (20 Years)	
1	100%	100%	Defective product value with the replacement cost of labor and freight
2	100%	100%	
3	90%	90%	Defective Product Value (Regular maintenance is required)
4-5	80%	75%	
6-8	70%	60%	
9-11	60%	40%	
12-14	50%	25%	
15-17	40%	10%	
18-20	30%	5%	
21-23	20%	/	
24-26	10%		
27-30	5%		

This warranty does not include any damage caused by a third party (such as the transporter).

4. After-sales service

- The customer complaints should be sent directly to sales@fjgoldenebamboo.com in written REBO® products claim form, attached with the corresponding on-site pictures, valid maintenance records, and valid replacement cost proof.

Fujian Golden Bamboo Industry Co., Ltd. reserves its right to inspect and verify the site of customer complaint.

