

# Datasheet of 360° LED 2G11

(10W/15W/18W/23W)

## Qualification

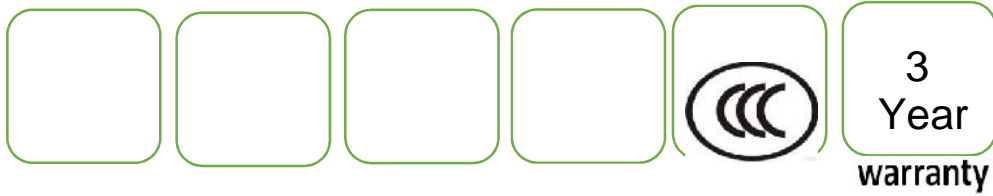

## Features

- The led 2G11 tube can replace both Osram and Philip Dulux compact Fluorescent tube
- High lumen Epistar 2835 SMD.
- Aluminum housing and PCB is good for heat dissipation.
- Isolated driver, constant current, Rubycon capacitor making lamp work stably, no flicking.
- UL/cUL, CE, RoHS certificates
- 5 years warranty

**Replace**





High quality and simple installation

Typically used in garden , commercial buildings, parking garages and etc...

Replacement of traditional halogen lamp



## Specification

	<b>ECO-2G11-9W- 360</b>	<b>ECO-2G11-15W -360</b>	<b>ECO-2G11-18W -360</b>	<b>ECO-2G11-23W- 360</b>
Input Voltage	AC100-277V			
LED light source	Epistar 2835 SMD			
LED Qty	144pcs	144pcs	208pcs	320pcs
Rated Power	9W	15W	18W	23W
Luminous Flux	960LM	1600LM	1920LM	2460LM
Dimension	225*41*18mm	320*41*18mm	410*41*18mm	535*41*18mm
Net weight	180g	240g	240g	330g
Base	2G11			
Lampshade	Clear/Milky			
Color Temperature	2700-6500K			
CRI	Ra>83			
Power Factor	>0.95			
Working Temperature	-20~+40°C			
Beam Angle	360°			
Lifespan	50.000hrs			

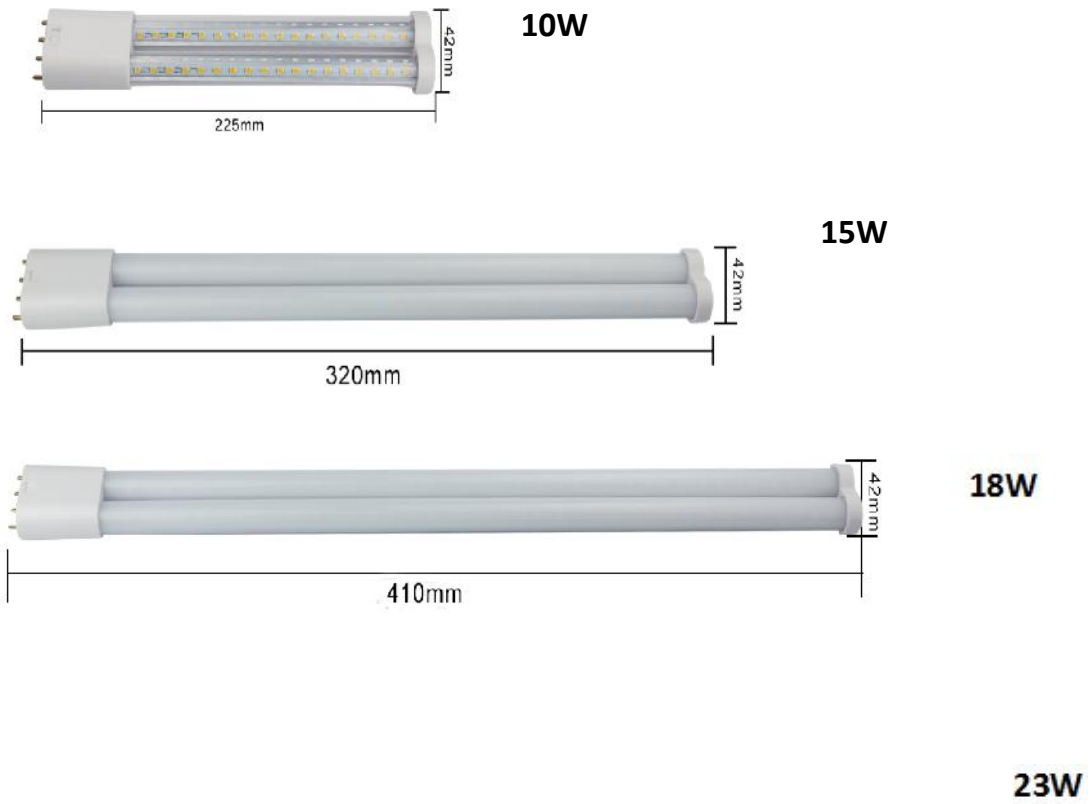

### Production process

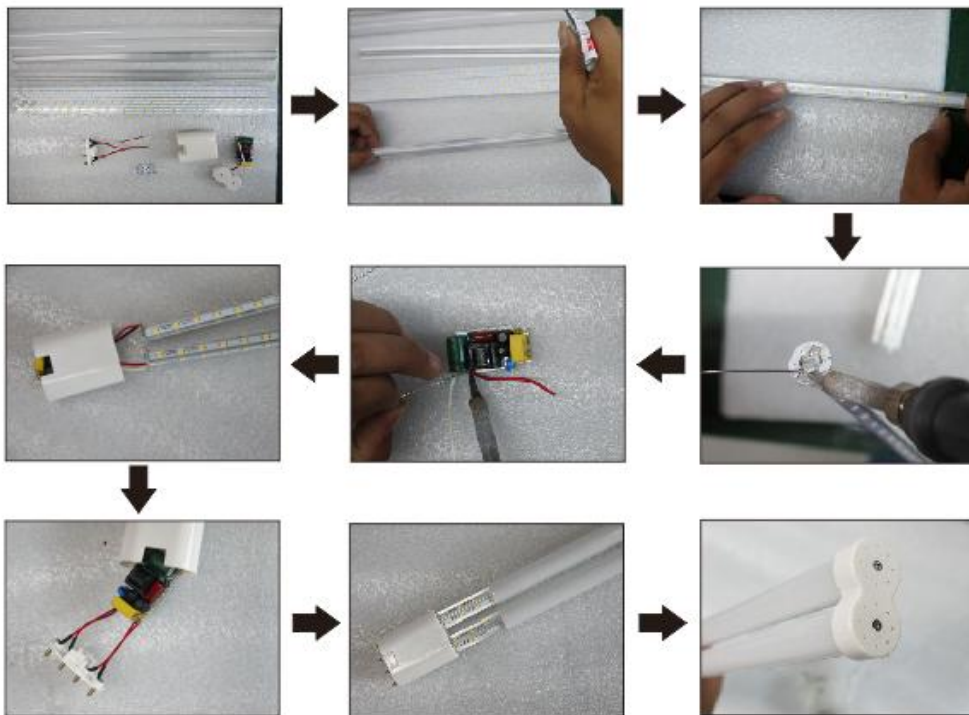

## Installation Notes

(1) If magnetic ballast

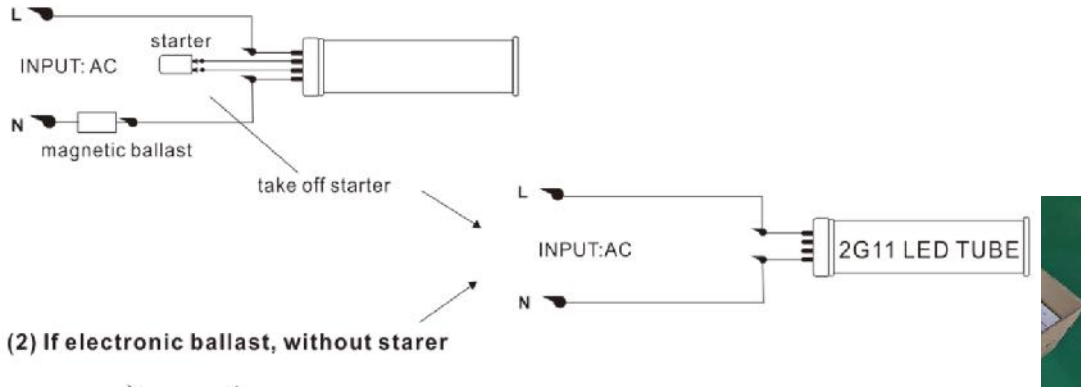

(2) If electronic ballast, without starter

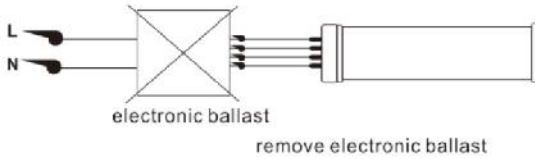

## Replace

	
<b>Wattage</b>	<b>CFL</b>
10W	18W
15W	23W
18W	40W
23W	55W

## Applications

It can be used in Residential Buildings, Home, Office, Meeting Room, School, Library, Factory, Warehouse, Hotel, Casino, Parking Garage, Hospital, Commercial Center, Supermarket, Shopping mall, anywhere you want.

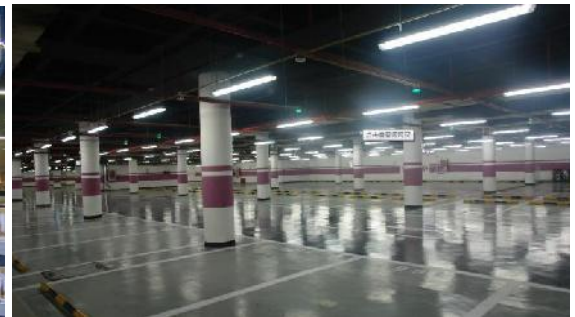

Supermarket

Parking Garage

Factory

School